

Flowmeter Installation Instructions

F-300

F-300

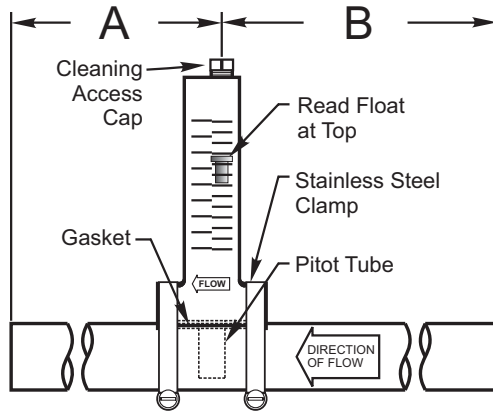

Dimension	Accuracy (L2 and L3)
A	Outlet pipe length = 2 x Pipe I.D.*
B	Inlet pipe length = 5 x Pipe I.D.*

* Minimum acceptable dimensions. Must be straight horizontal piping.

Models with suffix "P" = PVC pipe, Schedule 40 and Schedule 80 (IPS pipe, ASTM - D-1785)*
Models with suffix "T" = COPPER TUBING, Type "K" or "L"
Models with suffix "M" = PVC pipe, PN10 and Pn16

Installation: To prevent debris from entering the meter, install the flowmeter downstream from the filter if possible, with at least the minimum straight pipe dimensions called for in installation drawings. Drill the pitot tube hole in the top (12 o'clock position) of horizontal pipe. Carefully remove all burrs. Insert the pitot tube, with gasket in place, into the drilled hole. Tighten the clamps alternately, a little at a time. Make certain the flow direction is towards the pitot tube opening.

Flowmeter size	Drill size for pitot tube
1" thru 4"	5/8" to 41/64"
6" thru 8"	3/4" to 49/64"

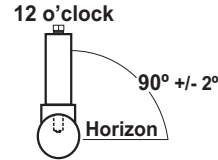

Maintenance: Should the meter fail to read, make certain the openings in the front and rear of the pitot tube are not clogged, that the pitot tube opening faces the direction of the flow, and that you have installed the meter on the correct IPS (ASTM-D-1785) type and size pipe. Periodically clean the inside of the meter with a soft bottle brush and mild soap solution. Note that the top of the float is the largest diameter.

Accuracy = +/- 7% (L2), +/- 10% (L3)

Max Temperature = 190°F / 87.7°C,

Maximum Pressure = 75 psi / 5.2 bar

Headloss = Maximum 1 psi across all pipe sizes

Pressure and temperature limits are inversely proportional

Blue-White® flowmeters are tested and calibrated for water only.

*NSF 50 listed for 1", 1.25", 1.5", 2" (L2), 2.5", 3", 4", and 6" (L3)

Blue-White®
Industries, Ltd.

5300 Business Drive
Huntington Beach, CA 92649

Phone: 714-893-8529
 Fax: 714-894-9492
 E-mail: TechSupport@Blue-White.com
 E-mail: Sales@Blue-White.com
 web: www.blue-white.com

80000-557
06092017

Maintenance

Minimal flowmeter maintenance is required. Should the meter fail to read, make certain the pitot tube opening is unobstructed, that the pitot tube opening faces the direction of the flow, and that you have installed the meter on the correct type and size pipe.

Cleaning

The flowmeter body and all other parts can be cleaned by washing in a mild soap and water solution. A soft bristle brush will simplify cleaning inside the meter body. Note the float's up position for re-assembly.

Maximum Temperature = 190°F at 0 Psi (87.8°C at 0 Bar)

Maximum Pressure = 75 PSI at 70°F (5.2 Bar at 21.1°C)

Accuracy = +/- 7% (L2), +/- 10% (L3)

Headloss = Maximum 1 psi across all pipe sizes

Pressure and temperature limits are inversely proportional.

We cannot guarantee our flowmeters will not be damaged either at or below the suggested limits simply because of many factors which influence meter integrity; stress resulting from meter misalignment, damage due to excessive vibration and/or deterioration caused by contact with certain chemicals as well as direct sunlight. These situations and others tend to reduce the strength of the materials from which the meters are manufactured. Flowmeters are tested and calibrated for water only.

Meters are suitable for indoor and outdoor use.

Although meters may be suitable for others chemicals, Blue-White cannot guarantee their suitability.

For more information visit our website at www.Blue-White.com

Blue-White[®]
Industries, Ltd.

5300 Business Drive
Huntington Beach, CA 92649

Phone: 714-893-8529

Fax: 714-894-9492

E-mail: TechSupport@Blue-White.com

E-mail: Sales@Blue-White.com

web: www.blue-white.com