

# WATERCO

Water, the Liquid of Life

## WATERCO

Water, the Liquid of Life  
www.waterco.com

### Fitting and Operating Instructions

#### Gemini / Filterking Water Purifiers



Clean,  
Healthy Water  
at the Touch of a tap!



Innovative Designs For Everyday Living!

#### To Ensure the Purest Water Possible

- \* Restrict the flow rate to 1-3 litres per minute. If the resulting flow rate is more than 3 litres per minute, use a flow inhibitor.
- \* Flush your purifier for 5-10 seconds each time you use it.
- \* Regularly maintain the filter and purifying cartridges.
- \* If filter is not in use for more than 24 hours, flush filter for a minimum of 1 minute prior to using.

#### Replacement Intervals

The replacement intervals of both cartridges are dependent on water quality and the volume of water passing through the filter:

- ◆ If flow is affected, it is time to change the Sediment Cartridge in the first housing. As a general guideline the Sediment Cartridge should be changed every 6-12 months.
- ◆ If taste/ odour is affected, it is time to change the Purifying Cartridge in the second housing. As a general guideline the Purifying Cartridge should be changed every 8-12 months.
- ◆ If you have installed a Filterking, if either flow or taste/ odour is affected please change the carbon cartridge. If the flow is affected within a short time period, Waterco recommends the installation of a Gemini Undersink Unit with a 5 micron pre-filter.

<b>Sediment Cartridges</b>	<ul style="list-style-type: none"> <li>• 5 Micron Sediment Cartridge (3651993)</li> </ul>
<b>Purifying Cartridges</b>	<ul style="list-style-type: none"> <li>• Extruded Carbon Block 1 micron (3651970)</li> <li>• Ceramic Cartridge 1 micron (3649020)</li> <li>• CZR/ Carbon Cartridge (3651919)</li> <li>• Extruded Carbon Block 5 micron (3651971)</li> </ul>

#### Troubleshooting

Problem	Reason	Solution
Water has an offensive odour	Sediment/ Carbon filter are depleted	Replace filters, clean system.
Not enough water	Low water pressure	If line pressure is below 30psi install a booster pump.
	Water supply is blocked	Clear restriction.
No water	Clogged pre-filter cartridge	Replace prefilter.
	Water supply is turned off	Turn on water.
Under sink is wet	Leak from valve, faucet or fitting	Dry everything to isolate the leak. Before replacing any fitting, reseat the tubing and reinsert into the fitting to see if that solves the leak. If pipe threads are leaking, remove and retape with Teflon tape.

#### Please Use a Skilled Installer

Damage caused during installation can void your warranty. Find an installer who is prepared to guarantee their workmanship.

Your warranty covers faulty parts, but does not cover leaks that appear during or after installation and does not cover any water damage that may result from such leaks.

#### Warranty

Waterco 12 month warranty. Void if correct fitting and operating instructions are not observed.

#### Waterco Limited ABN 62 002 070 733

##### OFFICES - AUSTRALIA

##### NSW (HEAD OFFICE)

Sydney  
Tel : +61 2 9898 8686  
Fax : +61 2 9898 1754

##### QLD

Brisbane  
Tel : +61 7 3299 9900  
Fax : +61 7 3299 9911

##### WA

Perth  
Tel : +61 8 9344 5533  
Fax : +61 8 9344 5506

##### SA/ NT

Adelaide  
Tel : +61 8 8244 6000  
Fax : +61 8 8244 6011

##### VIC/ TAS

Melbourne  
Tel : +61 3 9879 5141  
Fax : +61 3 9879 5143

##### DISTRIBUTOR ACT

Canberra  
Tel : +61 2 6280 6476  
Fax : +61 2 6280 9365

##### OFFICES - OVERSEAS

##### NEW ZEALAND

Auckland  
Tel : +64 9 525 7570  
Fax : +64 9 525 6580

##### MALAYSIA

Kuala Lumpur  
Tel : +60 3 6250 8169  
Fax : +60 3 6250 8175

##### UNITED STATES OF AMERICA

Phoenix  
Tel : +1 602 434 4703  
Fax : +1 602 434 4704

##### CHINA

Guangzhou  
Tel : +8620 8335 1107  
Fax : +8620 8335 1114

##### EUROPE

Lacron (UK) Ltd  
Kent, United Kingdom  
Tel : +44(0) 1795 521 733  
Fax : +44(0) 1795 522 085

Waterco stocks an extensive range of water filtration products, contact your local Waterco stockist for more information. Or visit our website at [www.waterco.com](http://www.waterco.com)

Distributed By :

(W99151) 06/ 2004

## Gemini/ Filtering Water Purifiers

### Fitting and Operating Instructions

Please read this entire guide prior to beginning installation.

The Gemini/ Filtering drinking water purifier has been designed for quick and simple installation and maintenance. By carefully reading this instruction manual and following the operational guidelines you will ensure a successful installation and reliable operation.

Do not use on water that is microbiologically unsafe or of unknown quality. The Gemini/ Filtering is normally installed under a sink or basin, but can also be plumbed-in or wall-mounted. In all cases you need a pressurised, sterilised and drinkable cold water supply.

Your Gemini/ Filtering is supplied with an installation kit that allows connection to a dishwasher type cold tap with a 3/4" BSP male thread. If a convenient tap is not available, you may either have one installed or purchase the suitable inlet fittings from your supplier.

### Components

Check the following list of components to ensure that all parts are packed with your system.

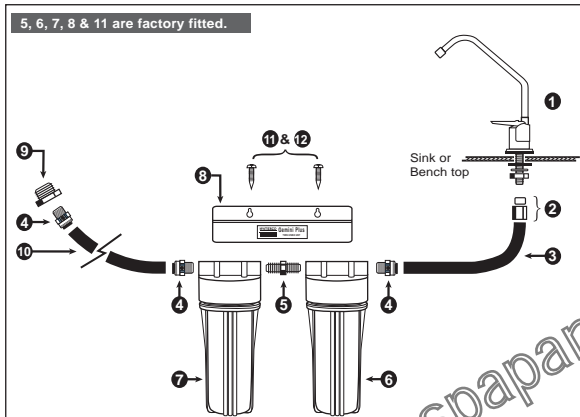

- |   |  |
|---|--|
| 1. Faucet set.                                    | 7. Filter housing with Sediment Cartridge.         |
| 2. 1/4" BSP nut with brass olive.                 | 8. Mounting bracket.                               |
| 3. 6mm blue tube x 1m.                            | 9. 3/4" x 1/4" BSP brass reducing coupling.        |
| 4. 1/4" BSP John Guest Straight Adaptor (3 sets). | 10. 6mm yellow tube x 1m.                          |
| 5. 1/4" x 1/4" BSP nipple.                        | 11. Filter housing's mounting screws (8 supplied). |
| 6. Filter Housing with Purifying Cartridge.       | 12. Wall mounting screws with plugs (2 supplied).  |

\* Filtering consists of only one filter housing with an extruded carbon block and a single mounting bracket.

### Installation

#### Faucet Installation.

1. Decide the location of the faucet on top of the bench top or sink top. This should not be more than 1.8m from the cold water supply. Make sure that drilling a 7/16" diameter hole in that location will not damage pipes or wires running under the sink.
2. Place a piece of masking tape or duct tape on the determined location where hole is to be drilled.
3. Use a variable speed drill at slow speed with 1/8" (3mm) drill and drill a centering hole in the center of the desired faucet location. Use lubricating oil to keep the drill bit cool while drilling.
4. Enlarge the hole using a 1/4" (6.4mm) drill bit.
5. Enlarge the hole to 7/16" (11mm) diameter. Keep bit well oiled and drill slowly.
6. Pass the Escutcheon Plate (chrome base plate) and the Black Rubber Washer in that order onto the shank on the base of the faucet.
7. From under the sink, install the Black Locating Washer and the Lock Washer over the threaded shank. Screw on the Lock Nut and tighten.
8. Sleeve the Compression Nut and the Ferrule over the Blue tube, insert the Tube Insert and push to the end of the threaded stem. Screw on the Compression Nut and tighten with a spanner.

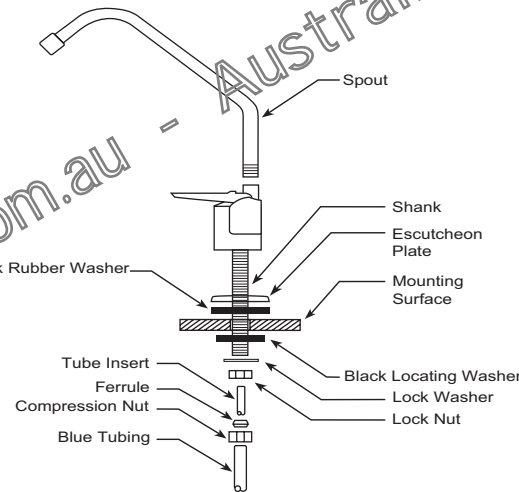

#### Housing Installation

1. Using the filter housing assembly to mark the position of the 2 mounting screws, making sure there is room for maintenance, drill 2 x 3mm holes for the mounting screws. Insert the wall plugs; screw the screws in the gap for the Mounting Bracket.
2. Apply 2 turns of Teflon tape to the nipple side of the John Guest Adaptors (items 4). Screw the nipples into the inlet and outlet of the filter housing assembly. Connect the blue tube to the outlet side and the yellow tube to the inlet side. Screw the nipple on the other end of the yellow tube into the 3/4" x 1/4" BSP brass reducing coupling (item 9).

#### John Guest Fittings and Tubing

John Guest fittings are used throughout the system.

1. To install the tube, push it through the collet until it seats firmly. The collet has stainless steel teeth which grip the pipe whilst the o-ring provides a permanent leak-proof seal. Pull on the pipe to check it is secure. It is good practice to test the system prior to leaving the site and/ or before use.

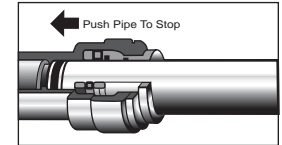

2. To remove the tube, please ensure the system is depressurised. Push in the collet squarely against the face of fitting. With the collet held in this position, the tube can be removed.

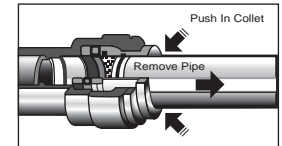

#### Plumbing the system

1. Locate the water shut-off valve for the cold water feed line you choose to use for the supply. To assure you are using the cold water line, turn on both the hot and cold faucet. After the water is warm to touch, feel the pipes under the sink. It will be easy to identify the hot and cold pipes.
2. Close the cold water valve. Turn on the cold water faucet to assure that the line is completely shut off and the line is drained. If no shut off valve is located underneath the sink, turn off the main supply at the entry to the house.
3. The Gemini/ Filtering is supplied with an installation kit that allows connection to a dishwasher type cold tap with a 3/4" BSP male thread. If a convenient tap is not available, you may either have one installed or purchase the suitable inlet fittings from your supplier. Connecting to the cold water main will require a qualified plumber. There must be a tap to turn off the water for maintenance. Use cold water only.

#### Warning !

Excessive pressure or water hammer can damage plumb-in systems. Do not, under any circumstances, connect to a pressurised water supply without testing pressure with an accurate gauge. If pressure is above 125 psi (875 kPa) day or night, or if any water hammer problems exist, a high quality pressure limiting / anti-hammer valve must be installed.

A non-return valve must be installed in the water supply line or between the supply line and the first filter housing. This will ensure no water returns to the supply.

The responsibility must always lie with the installer to check the water-tightness of all fittings and connections after the product is subjected to full line pressure. The installation must be checked last thing at night and again early the next morning after the day of installation, to make sure there are no drips from inadequately sealed connections.

#### Activating the system

Once the Gemini/ Filtering is connected, open the faucet before turning on the tap to displace air inside the filters. Let the water run for at least 5 to 10 minutes to flush the filter of fines (these particles are harmless). Turn the faucet off and check for leakage. Recheck overnight.

#### Operation

The spout can be rotated through 360° for added convenience.

When small amounts of water are required from the faucet, push down or gently pull up on the faucet handle.

For large amounts of water delivered hands-free from the faucet, pull up on the faucet handle until it locks into the open position.