

SMARTOUCH DIGITAL

Series

1000 & 2000

USER

PROGRAMMING

MANUAL



701 W. Foothill Blvd Azusa CA 91702
(626) 969 - 9655 Fax (626) 334 - 4809

SmarTouch Digital controls are microprocessor based electronic spa control systems and as such are susceptible to static discharge and high levels of humidity. To prevent premature control failure do not hose down, flood or allow water to enter the control box enclosure.

CAUTION

High voltage levels exist inside the control box, they can cause injury and even electrocution.

Only certified electricians or trained servicemen should have access to the components inside the box.

There are no user serviceable parts inside the box. All programming is done at the spa side control panel without the need to access the inside of the box. If for some reason the control system needs to be serviced, please contact Applied Computer Controls for proper procedures.

Model # _____ Serial # _____

Software Rev # _____ Purch Date ____ / ____ / ____

Device	120V	240V	1Sp	2Sp	12V	Installed
Primary Pump	<input type="checkbox"/>	<input type="checkbox"/>	<input type="checkbox"/>	<input type="checkbox"/>	<input checked="" type="checkbox"/>	<input type="checkbox"/>
Circulating Pump	<input type="checkbox"/>	<input type="checkbox"/>	<input type="checkbox"/>	<input type="checkbox"/>	<input checked="" type="checkbox"/>	<input type="checkbox"/>
Second Pump	<input type="checkbox"/>	<input type="checkbox"/>	<input type="checkbox"/>	<input type="checkbox"/>	<input checked="" type="checkbox"/>	<input type="checkbox"/>
Third Pump	<input type="checkbox"/>	<input type="checkbox"/>	<input type="checkbox"/>	<input checked="" type="checkbox"/>	<input checked="" type="checkbox"/>	<input type="checkbox"/>
Air Blower	<input type="checkbox"/>	<input type="checkbox"/>	<input type="checkbox"/>	<input checked="" type="checkbox"/>	<input checked="" type="checkbox"/>	<input type="checkbox"/>
Spa Light	<input type="checkbox"/>	<input type="checkbox"/>	<input checked="" type="checkbox"/>	<input checked="" type="checkbox"/>	<input type="checkbox"/>	<input type="checkbox"/>
Fiber Optic Light	<input type="checkbox"/>	<input type="checkbox"/>	<input checked="" type="checkbox"/>	<input checked="" type="checkbox"/>	<input type="checkbox"/>	<input type="checkbox"/>
Fiber Optic Wheel	<input type="checkbox"/>	<input type="checkbox"/>	<input checked="" type="checkbox"/>	<input checked="" type="checkbox"/>	<input type="checkbox"/>	<input type="checkbox"/>
Spa Mister	<input type="checkbox"/>	<input type="checkbox"/>	<input checked="" type="checkbox"/>	<input checked="" type="checkbox"/>	<input type="checkbox"/>	<input type="checkbox"/>

TABLE OF CONTENTS

INTRODUCTION	4
IN A HURRY	5
Setting Temperature	5
The SET Key	5
Time Of Day TOD	6
Setting TOD	6
THE CONTROL PANEL	7
DEVICE CONTROL GROUP	7
Primary Water Pump	7
Air Blower	8
Auxiliary Pump(s)	8
Spa Light	8
Summary of Device Functions	9
STATUS CONTROL GROUP	10
The TEMP key	10
The TIME key	11
The SET key	11
PROGRAMMING THE SC-1000 & SC-2000	12
Parameter Programming	12
Programming Example	13
PROGRAMMING SYSTEM OPTIONS	17
User Options	17
Protected Options	19
Diagnostic Values	20
ERROR MESSAGES	21
CoLD, OH, LHoH	21
SEoP, SESH, PSoC, PSoL, PSoH	22
ToE - Time out error	22
ELECTRICAL COONECTION INSTRUCTIONS	23
BRANCH CIRCUIT BREAKER REQUIREMENTS	24

INTRODUCTION

Thank you for buying a spa equipped with a SmarTouch Digital control systems. Many years of experience went into the design of this family of controls. You can be assured your spa control system is the most advanced, it is highly reliable and will serve you for many years to come.

The control system has been designed with the you the user in mind. It is very easy to operate and requires a minimal effort on your part. You may use it just as it comes to you and without any programming. Yet you have the option of getting deeply involved in the inner workings of the control if you so choose. You can custom tailor it to fit your needs.

Please take the time to read at least the first section (next page) "IN A HURRY - READ THIS" portion of the manual before starting to use your spa for the first time. You can familiarize yourself with the rest of the manual at your leisure. This manual will also serve as a reference if you choose to modify the operation of your spa.

SAVE THIS MANUAL.

Make it available for other spa users.

You should also have a spa user's manual which explains how to care for your spa. Please read and follow all instructions in your spa user's manual. Maintaining the proper levels of pH and the sanitizer will extend the life of your spa equipment. Improper chemical levels in the spa are sure to cause premature heater failure as well as failure of other components in the system. Failures caused by chemical imbalance are not covered by warranty.



IN A HURRY - READ THIS

For those who don't like to read manuals or would like to read the manual later, please read at least the following section.

SmarTouch Digital comes to you with a universal set of default settings. If you choose to keep these settings, then you only need to remember 2 things : how to set the spa temperature and to press the SET key whenever you are done using the spa.

Setting Temperature

- ◆ Press and hold the TEMP key for 2 seconds. Release all keys. The display will flash the current selected temperature.
- ◆ Using the TEMP and TIME keys (UP and DOWN arrows) scroll to the desired temperature.
- ◆ Press the SET key to lock in the new selection

The SET Key

After using the spa, press the SET key to tell the microcontroller you are done using the spa. It will then take over the spa's management including the different filtration cycles, heat maintenance, economy modes and protection against freezing.

Upon entering this mode the FILTER light is turned on and a post use filtration cycle is executed - that is when the spa needs filtration the most. The default system setting includes a 3 hour economy mode, the pump will come on at most once every 3 hours to sample water temperature and heat if necessary. The controller remembers when you have used the spa and in anticipation of your next usage will perform a 3 hour Auto Filtration cycle before your next spa use.

SmarTouch Digital Series 1000 and 2000 is a family of intelligent, spa control systems. These systems are rich with features and can be extensively programmed to fit just about any need. The rest of this manual will explain the function of each of the keys on the control panel, how to change programmed settings and what each setting does. It will also explain all the error messages that you may encounter, and their significance and way to correct them.

Time Of Day (TOD)

SmarTouch Digital maintains a 12 hour AM / PM internal real time clock TOD (Time Of Day). The clock based on the line frequency. There is no battery backup and whenever the power is turned off, TOD is no longer correct. It defaults to 12:00 AM whenever the power is turned on.

Setting TOD is only necessary if you are going to program the filtration and silence cycles. If you use the factory default settings then you do not need to set TOD.

If you set TOD then SmarTouch will display time every first 10 seconds of each minute. If TOD has not been set then it will not be displayed.

Setting TOD

1. Press and hold the TIME key for 2 seconds. Current TOD will be displayed with the hour portion flashing.
2. Release the TIME key.
3. Using the TEMP and TIME keys scroll up and down to the desired hour: - Notice the AM / PM Led.
4. When the correct hour and AM / PM are displayed press the SET key to lock in the new hour.
5. The display will now flash the minutes portion of current TOD.
6. Using TIME and TEMP scroll to the desired minutes.
7. When the correct minutes are displayed press the SET key to lock in the time of day (hours and minutes)

Note : TOD is the only parameter in SmarTouch Digital that is not preserved on power down. On power up it will default to 12:00 AM, all other parameters are restored to the their last setting.

Every time the controller is powered up, the microprocessor automatically measures and determines whether the line frequency is 50 or 60 cycles in order to maintain the correct TOD.

THE CONTROL PANEL

The control panel is normally installed on the lip of the spa for easy and convenient access. Within the panel housing is a 4 digit LED display used to communicate to the user spa temperature, TOD, elapsed user time, programming, status - diagnostic and error codes and messages. There are 2 different size panels. They are interchangeable. the 2000 Series panel can have up to 7 keys, the 1000 Series panel will have at most 6 keys. These are membrane type switches which when depressed generate a signal that the microprocessor will interpret and act upon. The switches are labeled and have specific functions. They are divided into 2 groups:

Device Control Group Pump(s), Air Blower & Spa Light
Status Control Group: Up & Down Keys & the Set Key.

Note: if any of the keys is pressed and held closed for longer than 20 seconds, that key will be disabled and becomes non functional. After releasing the key, it will be reactivated after 20 seconds. This is to prevent a collapsed or defective key from locking up the system.

DEVICE CONTROL KEYS

There are up to 4 device key, JETS, AIR, AUX & LITE. Your spa will have at least one water pump. Optionally your spa may have an air blower, a second and/or third pump and a spa light. It may also have a mister or a fiber optic light setup. If your spa does not have a specific device please disregard the function of that device.

Primary Water Pump

Each spa should have at least one primary water pump which is usually a dual speed pump. The low speed is used to filter the spa. Also while the spa is being heated or there is an error condition, the low speed circulates the water and you will not be able to turn it off.

The **JETS** key (switch) on the control panel is a 3 position switch : Low Pump, High Pump, Off. Each time the key is pressed, the next function is executed. If your primary pump is a single speed pump then only the high pump will be activated. 2 LED indicators, LO & HI inform you which speed is on.

Note : if your spa is equipped with a circulating pump it will be used for filtration and heating instead of the low speed pump.

Air Blower.

If your spa is equipped with an air blower (bubbler), it is activated by the **AIR** key. This is an ON/OFF key. An LED will indicate when the air blower is on.

Auxiliary Pump(s).

Your spa may be equipped with 1 or 2 more pumps. If you have a second pump, it could be a single speed or a dual speed.

If you have a third pump then both the second and third pumps must be single speed. The function of the **AUX** key changes with the number and type of auxiliary pumps used. Please consult with the table on the following page for the proper sequence of activation.

Spa Light

The **LITE** key can also be a multifunction key. In its simplest configuration, the **LITE** key is a simple on / off switch. It turns the spa light and the accessory, if one is attached, on / off together at the same time. Alternatively the LITE key may be programmed as a 3 function key. Pressing it once will turn the spa light on. Pressing it a second time will turn on the attached accessory, while the light is still on. Press it a third time and both spa light and accessory will go off.

The table on the following page summarizes all the possible device key combinations. Please note that your spa may not necessarily have all these devices attached.

SUMMARY OF FUNCTIONS FOR EACH DEVICE

Key	Device	1	2	3	4
	Single speed pump	ON	OFF		
JETS	Dual speed pump	LOW	HIGH	OFF	
	Dual speed with Circ pump Circ pump is independent	LOW	HIGH	OFF	
AIR	Single speed air blower	ON	OFF		
	One single Speed pump	ON	OFF		
AUX	One dual speed pump	LOW	HIGH	OFF	
	Two Single speed pumps	P1	P1&2	P2	ALL OFF
	Spa light	ON	OFF		
LITE	Spa Light & Accessory	Both ON	Both OFF		
	Spa Light & Accessory 3 Function	Lite ON	Both ON	Both OFF	

Table 1 - Device keys summary of functions

The four device keys, JETS, AIR, AUX and LITE are exclusive, when one is pressed, no other key may be pressed simultaneously. You must release the pressed key before you may press another key. Also these keys do not repeat.

If you press and hold a key for more than 20 seconds that key will be considered defective (collapsed) and will be deactivated and ignored by the system. When released the key will stay inactive for 20 seconds before it is recognized and activated.



STATUS CONTROL KEYS

The keys in this group are used to communicate to the controller system settings and option selection(s). There are 3 keys in this group and 3 functions that are combinations of these keys:

Key Press	Function
TEMP (up arrow) TIME (down arrow) SET key.	Prog Temp, + or Next Prog TOD, - or Previous Select or Accept , Enter
SET & TEMP	Invert display
SET & TIME	Parameter programming
TEMP & TIME	System programming

Table 2 - Status Control Keys Summary

The **TEMP** key , which is also the UP ARROW key, is a repeat key if held down. Think of this key as “+ or next”. Use it to :

- ◆ Press and hold for 2 seconds then release it to start desired temperature selection.
- ◆ During temperature setting press TEMP to increase selected temperature.
- ◆ When doing system programming press TEMP to scroll to the next message.
- ◆ After message selection, the system displays the associated value, press TEMP to increase that value.

Note: When the display is inverted, you will be able to read the display from inside the spa ; the keys will retain their functions and will not be inverted. The UP ARROW will still function as the UP ARROW even though when you look at it from within the spa it appears to be the DOWN ARROW. The same also applies to the rest of the keys.

The **TIME** key , which is also the DOWN ARROW key, is also a repeat key. Think of it as “ - or previous”. Use it to :

- ◆ Press and hold for 2 seconds then release it to start setting the real time clock (TOD)
- ◆ During time setting press TIME to decrease the hours or minutes value that is being set.
- ◆ When doing system programming press TIME to scroll to the previous message
- ◆ After selecting a message, the system displays the associated value, press TIME to decrease that value.

The **SET** key is equivalent to Select or Accept. It functions as an Enter key of a personal computer, it is the proverbial “hit any key to continue”. Press the set key to:

- ◆ After using the spa press the SET key to tell the controller to take over the management of the spa.
- ◆ During temperature setting press the SET key to lock in a new selected temperature.
- ◆ During time of day programming press the SET key to lock in the hour and the minutes.
- ◆ When a message is displayed during parameter programming, press SET to select that message.
- ◆ When a parameter value is displayed, press SET to accept the displayed value and return to message display.
- ◆ During option programming press SET to toggle a parameter On or OFF.
- ◆ When a “**HLoH**” error message is displayed press the SET key to clear the error (if the the cause has been corrected). Pressing the SET key, the user acknowledges that the cause of the hi limit error has been or will be corrected.

Note: UP is synonymous with TEMP and DOWN is the same key as TIME. These are used interchangeably and mean the same thing. Scrolling means pushing either the UP or the DOWN key to go to the next or previous item or value.

PROGRAMMING SC1000 & SC2000

Parameter Programming is a means by which the spa owner / user can change the various timing elements and calibrate temperature. The process is simple and intuitive. Only 3 keys are used: UP, DOWN and SET. To program one or more parameters follow the outlined this procedure:

1. Press SET and DOWN keys together. The first message in the menu, FP1 will be displayed.
2. Use the UP & DOWN keys to scroll thru the messages in the menu.
3. Press the SET key to display the current value associated with the current message.
4. Use UP or DOWN keys to increase or decrease the value.
5. Press SET to lock in the new value and return to the menu.
6. If another item needs programming go to number 2 above.
7. To save changes scroll to message SEND and press SET.
8. To discard changes and restore previous values scroll to message CANC and press SET.

The menu of parameters is circular. Scrolling is from first to last or from last to first.

When in programming mode please note that this mode will be cancelled if there is no key activity for a period of 60 consecutive seconds. Programming mode is aborted and all changes will be restored to previous values.

On the following page is an example of how to program a filtration period. When in programming mode you may program as many parameters as needed.

Example: program filtration period 2 to start at 5:45 PM

Press	Display	Explanation
SET & UP	FP1	Start programming the display first message is Filtration Period 1.
UP	FP2	Scroll up to Filtration Period 2.
SET	12:00	Select FP2. The display shows the current FP2 start time with the hour portion flashing
UP	1:00	Increase the hour value by 1.
UP	5:00	5:00 Press UP key 4 more times or press and hold for auto repeat.
SET	5:00	The hour is set, the minute portion flashes.
DOWN	5:45	Press UP 15 times or press and hold for auto repeat.
SET	FP2	FP2 set to 5:45 PM & the current message is displayed again.
DOWN	FP1	Scroll to previous message.
DOWN	CANC	Previous message - if you press SET when CANC is displayed all changes will be discarded
DOWN	SEND	Previous - save changes
SET	Temp	Changes saved. Exit programming mode. Display current spa temperature, time or operating message.

The table on the following pages is a list of all menu items, their minimum, default and maximum values and an explanation of the function of each parameter.

Note : Time parameters have two components, the hours and the minutes. When programming a time element, first the hour portion is programmed (flashing). When the hours are set press the SET key to program the minutes portion.

PARAMETER MENU LIST

Msg	Min	Def	Max	Detail
FP1		12:00		Start time of filtration period 1
FP2		12:00		Start time of filtration period 2
FP3		12:00		Start time of filtration period 3
FP4		12:00		Start time of filtration period 4
<p>Note : If filtration periods overlap, the most recent period (last) is in effect.</p>				
SIL		12:00		<p>Start time of the silence period. This is a period during which nothing will run. It overrides all filtrations, the economy cycle, and temperature sampling. Except if temperature drops below 40 degrees. A spa may be installed near a bedroom and need not come on at specific times, for example between midnight and 7 in the morning.</p>
FP1d	0	0	240	Duration in minutes FP1 timer will run.
FP2d	0	0	240	Duration in minutes FP2 timer will run.
FP3d	0	0	240	Duration in minutes FP3 timer will run.
FP4d	0	0	240	Duration in minutes FP4 timer will run.
SILd	0	0	12	Duration in hours the Silence Timer runs. Only a user may override the silence timer

Note : Keep the value of any timer to 0 to keep it from running. Filtration timers must be programmed first one first. If the FP1d (first) timer has a duration of 0, Auto Filtration will be in effect and all 4 programmed timers will be disabled.

Msg	Min	Def	Max	Detail
CLDN	30	60	180	Cool Down cycle in seconds. Whenever the heater is turned off the pump keeps running the extra seconds to even the temperature of the heater element and the surrounding water to prevent scale build up and premature heater failure.
ECL	60	180	240	Economy Cycle Length. Time in minutes to specify the intervals between spa temperature sampling when the spa is not in use. During this period the spa is in sleep mode. Temperature is sampled at the end of the period. Press any key to cancel this mode
CHCL	0	60	180	Channel Clear. Time in seconds to clear the air channel and the secondary pump(s) plumbing if the spa has not been used for a period of 24 hours. This prevents water stagnation in the plumbing.
UTO	10	20	60	User Time Out. The time in minutes from starting any device, after which all devices will be turned of, and the spa put in "not in use mode". If you should leave the spa with a pump or light running, it will be turned off after the specified time.
PUF	30	60	180	Post Use Filtration. Time in minutes to perform Post Use Filtration this is the optimal time to filter the spa. When you have finished using the spa, that is when it needs filtration the most. Press the SET key to turn everything off and start this cycle. This cycle is performed only once and after pressing the SET key. It is in addition to the standard filtration cycles. Pressing any other device key will cancel this function.

Msg	Min	Def	Max	Detail
CALB	194	204	214	This is not a time element. It is one of the distinctive features of the SC1000 and the SC2000 systems. The number is internal and is indicative of what the processor sees as temperature. It is used to calibrate the temperature reading. Increase this value by 1 to decrease the displayed temperature by ½ a degree. Decrease this number by 1 to increase displayed temperature by ½ a degree. For example if the controller is displaying a temperature 2 degrees lower than real temperature increase the number by 4 to get a correct reading. The total range of this parameter is 10 degrees Fahrenheit. Before doing a calibration Please read warning note at end of this page.
SEND				This menu message has no numerical value. Pressing SET while it is displayed records and saves all changes made to all parameters.
CANC				This menu message also has no value. Pressing SET while it is displayed discards all changes made to all parameters and restores last saved or previous values.

WARNING

The recommended maximum temperature of a spa is 104°F. The absolute maximum beyond which no person should ever be exposed to is 108°F. When you calibrate the spa temperature you are doing so at your own risk. Obtain an accurate medical thermometer to check against. Please contact ACC for proper procedure or if you do not feel confident.

PROGRAMMING SYSTEM OPTIONS

System Options Programming is a means of setting the various system options. The U and P options are of the ON / OFF or 1 / 0 type; the option is either 1 or ON or it is a 0 or OFF. The D options can only be displayed. They may not be changed by the user. To initiate options programming press the UP and DOWN arrows together. There are 3 groups of 8 options each :

User options	U1 to U8
Protected options	P1 to P8
Diagnostics	D1 to D8

When programming groups 1 and 2, (U and P options) either the letter U or the letter P is displayed followed by a number (1 to 8), a space and the number 1 if the option was ON or a 0 if the option was OFF. For example if the third user option was OFF the letters U3 0 will be displayed. If it was ON the display will read U3 1.

Use the scroll buttons (UP and DOWN) to navigate thru the different options. Press the SET key to toggle a displayed option's status from 0 to 1 or vice versa. Go to SEND and press SET to save changes. Alternatively go to CANC and press SET to discard all changes and restore previous settings.

The Diagnostics are not options, but rather they display internal values that are indicative of the internal state of the processor. They are useful for a serviceman or a technician and to pinpoint hardware problems and error conditions.

The following tables list the User Options and the Protected Options and their significance when they are ON and OFF.

User Options

- U1 0 = Economy mode is on. In this mode water temperature is sampled every 3 hours or whatever ECL is set to. If the spa is being used the economy mode is off.
 1 = Auto Maintenance is on, temperature is sampled and acted upon continuously.

- U2 0 = Low pump on demand. The low pump will come on to sample temperature, heat or filter the spa as needed.
 1 = The low pump runs all the time.
- U3 0 = Auto Filtration is one 3 hour long period. This length of this period is fixed and cannot be changed. It is the minimum recommended filtration time for a spa.
 1 = Auto Filtration is two periods each 3 hours long. The second period starts 12 hours after the first period is executed.
- U4 0 = User timer starts with the first key pressed and shuts the spa off at the end of count down.
 1 = The user timer is restarted every time a key is pressed.
- U5 0 = Display TOD, time of day the first 10 seconds of every minute, if the time of day has been set.
 1 = Do not display TOD. If TOD was not set by the user then it most probably is incorrect and the controller will not display it even if U5 is a 0.
- U6 0 = If line frequency is 60 hz, then display temperature in Fahrenheit. If 50 hz then display Centigrade.
 1 = If line frequency is 60 hz, then display Centigrade. If 50 hz then display Fahrenheit.

Note : Line frequency is automatically measured by the microprocessor every time on power up and the displayed temperature will follow the frequency : Fahrenheit for 60Hz (US), Centigrade for 50Hz (Europe). When option U6 is set ON, the units of displayed temperature will be opposite to the frequency.

- U7 RESERVED do not change leave it at 0
- U8 RESERVED do not change leave it at 0

The default setting for all U options is 0.

Protected Options

Warning : Changing any of the Protected options may be dangerous and can result in injury. It can also damage the spa and it's equipment as well. Changes made by user are at the his/her own risk. All liability rests with the person doing the changes. Only trained service personnel should make changes. If unsure please contact ACC for more information.

- P1 0 = There is no additional circulating pump. The primary pump is usually 2 speed. The low speed is the filtering and heating pump
1 = A circulating pump is attached to the system
- P2 0 = The primary pump is a 2 speed pump.
1 = The primary pump is a single speed pump.
- Note : The circulating pump is always attached thru the heater. All filtration and heating is done with the circulating pump when one is attached to the system.
- P3 0 = The system has high amps available.
1 = The system is only capable of 20 or 30 amps, (low power).
In this mode the heater can only operate with the low or circulation pump. It is disabled with all other selections.
- P4 0 = The LITE key operates as an On/Off switch. The light relay and the accessory relay (if installed) operate together.
1 = The LITE key is a 3 function key:
- ◆ Press once, the spa light is turned on
 - ◆ Press again, both spa light on and accessory go on
 - ◆ Press a third itme for both functions to go off
- P5 0 = Reserved. Do not use this option.
- P6 0 = Air blower is enabled. The AIR key is active.
1 = Air blower is disabled. The AIR key is deactivated.

P7 0 = Secondary pump is a single speed pump.
1 = Secondary pump is a dual speed pump.

P8 0 = There is only one secondary pump.
1 = There are 2 secondary pumps.

Note : if P8 is ON, then by definition both secondary pumps must be single speed.

Warning : an improper setting of P7 and P8 can result in damaged or even destroyed pump motors. It can also cause the controller's printed circuit board to catch fire. Only trained service personnel should carry out changes. If unsure please contact ACC for more information.

DIAGNOSTIC VALUES

The D options are internal diagnostic values and may not be changed from the control panel. When a D message is displayed, press the SET key to see what the associated value is. Here is a brief explanation :

- D1 What the microprocessor is reading as relative temperature.
- D2 What the microprocessor is reading from the keys.
- D3 What the microprocessor is sending to the relays.
- D4 Accumulated count of temperature errors encountered.
- D5 Accumulated count of hi limit errors encountered.
- D6 Accumulated count of heartbeat errors encountered.
- D7 The firmware revision number.
- D8 The manufacturing year and week in the form yyww



ERROR MESSAGES

There are 9 error messages that a SmarTouch may generate. Here is a list of these messages and what they indicate:

CoLd Temperature in the spa heater housing is below 40* Fahrenheit. Because spa temperature should never get this low, the status of the heater element is unknown. Therefore the low speed pump or circulation pump will run continuously until temperature rises above 45*. A spa should not be filled with water below 40*. Please note that a running pump can heat the spa at approximately 1/2 degree F per hour. During this error condition, the spa is functional except for the heater.

OH OverHeat. The spa is at a temperature that is above 108°F. SmarTouch will not accept temperature setting above 104°F. If for some reason spa temperature rises over the maximum level, SmarTouch will display a flashing 105°F to 108°F. If temperature goes past 108 then the OH message will be displayed instead of temperature. The spa is still operational but hotter than any person should be subjected to. Please do not use your spa when the temperature is flashing or the OH message is displayed.

In the summer and especially in warm regions, ambient temperature may be high enough to overheat the spa naturally. Spas are usually well insulated and can store a lot of heat in the equipment compartment.

HLoH Hi Limit Over Heat. SmarTouch has a backup water temperature sensor called the Hi Limit. If the sensor is disconnected or shorted or if the spa temperature should reach above 112°F the Hi Limit protection circuitry will force all spa functions off and will flash the HLoH message on the display. It is not possible to use the spa when this error is in effect. Even after temperature goes down to an acceptable level or the sensor is repaired / replaced. When the error has been corrected, you must press the SET key to acknowledge that you, the spa user, are aware of the error condition and should have the proper repairs done.

SEoP Sensor Open or disconnected and SmarTouch cannot determine the spa temperature. The heater is disabled but the spa is operational. The sensor must be replaced or reconnected for this message to go away.

SESH Sensor Short. The sensor is shorted and is non functional. Temperature cannot be determined, the heater is disabled, but the spa is still operational. Sensor must be replaced to get rid of this message.

PSoC, PSoL, PSoH Pressure Switch Open with Circulating, Low or High pump(s). The pressure switch is a device sensitive to pressure inside the heater manifold. Pressure in the heater manifold is generated by a pump pushing water through the manifold. If one a pump is running and the pressure switch does not sense any pressure then there is an indication of no water flow. To prevent the heater from being turned on when there is no water running through the heater is turned off and one of these message will be displayed indicating which pump is supposed to be running.

A pressure switch error may also be indicated if the switch is out of adjustment or there is an air lock in the heater manifold. Adjusting the pressure switch is best left to a trained technician. An air lock may happen whenever the spa is drained and refilled with water, or if the water level in the spa is so low as to permit air to be sucked in by the pump. To bleed an air lock loosen one of the heater fittings a quarter of a turn while a pump is running. You will hear the sound of escaping air, then water will start dripping. Re-tighten the fitting.

ToE Time Out Error. It is not likely that you will ever see this error. It indicates that the system's heartbeat is out of control, all devices will be shut down and the spa is unusable. This message will rarely ever occur, if it does, please contact Applied Computer Controls..



ELECTRICAL CONNECTION INSTRUCTIONS.

NOTICE : All spa electrical wiring must be performed by a qualified licensed electrician and must meet all NEC (National Electrical Code) and state and local codes and requirements.

DANGER - RISK OF ELECTRIC SHOCK

1. The lines carrying power to the spa must be dedicated to the spa and should not be shared with any other appliance(s).
2. All electrical wiring lines must originate from the electrical panel and terminate, hard wired, into the electrical wiring compartment. The use of extension cords or plug type termination is expressly prohibited and voids the warranty.
3. Do not use aluminum wiring. Use only copper wiring.
4. Wire gauge must be in accordance with NEC requirements for the distance from current source to spa and the current rating as stated on the ID label that is attached to the control enclosure.
5. All wiring must be shielded by a grounded metal conduit. The conduit must terminate at the electrical access compartment either from the bottom of the spa or through a hole in the side paneling of the spa.
6. For a 120 volt system the line wire (black) is connected to the terminal block lug labeled LINE1. The neutral wire (white) is connected to the center lug labeled NEUT, and the ground wire (green) is connected to the ground lug labeled G or GROUND.
7. For a 240 volt 4 wire system, connect Line1, Neutral and Ground wires as in # 6 above. The fourth wire is the Line2 wire (red) and it is connected to the lug labeled LINE2.
8. For a 240 volt 3 wire system, connect black line wire to LINE1 terminal, connect red line wire to LINE2 terminal and the green wire to the ground lug. There is no neutral.

BRANCH CIRCUIT BREAKER REQUIREMENTS

240 Volts	4 Wire System	30/50 Amp 2 Pole Breaker
240 Volt	3 Wire System	30/50 Amp 2 Pole Breaker
120 Volt	3 Wire System	20 Amp 1 Pole breaker

CAUTION : A new breaker must be used for a new spa installation. Do not use an existing or used breaker.

GFCI. All spa installations must be protected by a GFCI. If your spa control box does not include an integrated GFCI then you must use a GFCI breaker per National Electrical Code requirements.

Note : If using a GFCI type breaker on a 240 Volt 3 wire system, the breakers's neutral (white) wire must not be used and should be capped with a wire a nut.

120/240 Volt Conversion All spas are shipped configured for 240 volt (3 or 4 wire systems). Please check the nameplate on the control enclosure to identify the type of system in your spa. If the nameplate indicates a 120/240 Volt type system, then it is possible to convert the spa to 120 volt operation.

30/50 Amp Conversion. Some homes may have limited power service. It is possible to operate a 240 volt spa system using a 30 amp breaker. Connect 240 volt power to the system as previously described, then set it to operate in the low power mode. To set the controller to operate in low power mode, you must set system option P3 to 1. Please read the note on page 18 and the warning on page 19.

Note: Only experienced service personnel should perform conversions. Improper modifications may cause damage to the control system and / or the attached heater and pump motors.

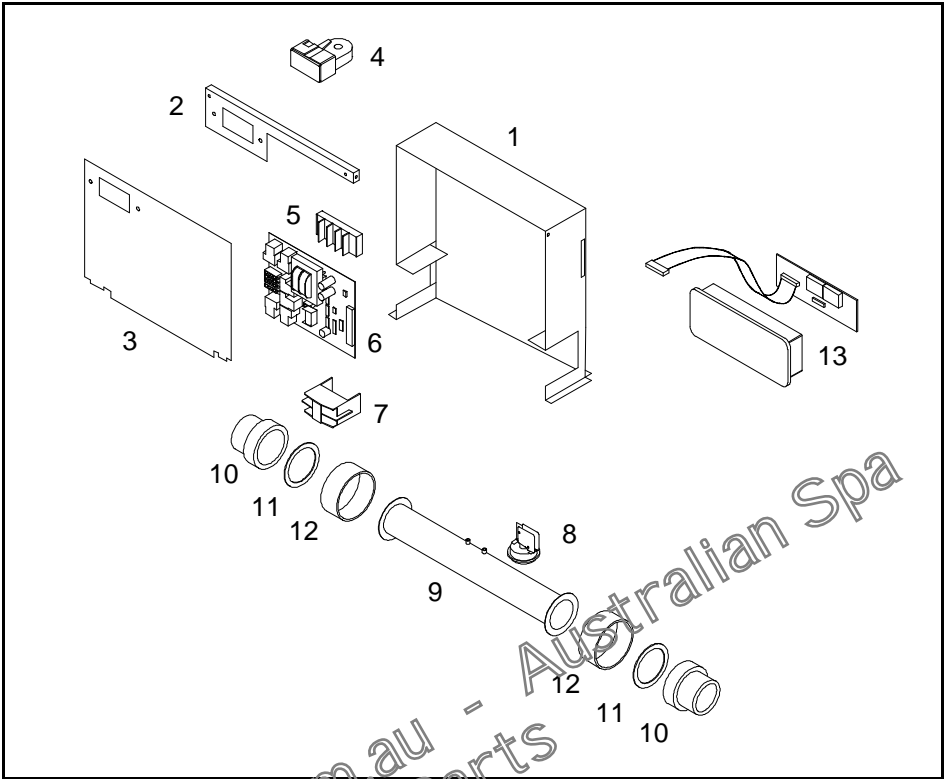

SmartTouch Digital Typical view - exploded

1. Enclosure Box
2. GFCI Flange
3. Cover Plate
4. GFCI (optional) - 120 volt 20 amp or 240 volt 50 amp
5. Terminal Block - 2 position or 3 position
6. Printed circuit control board - SC2000, SC1000, SC1100Jr
7. Heater contactor
8. Pressure Switch
9. Stainless steel heater manifold tube
10. Heater union, male fitting.
11. Gasket
12. Heater union, female fitting
13. Spa side control assembly

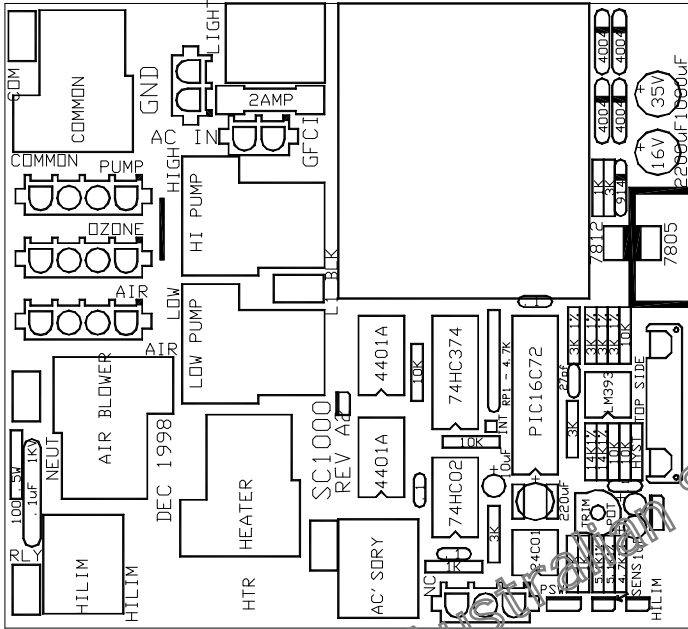

SC-1000 Control Board

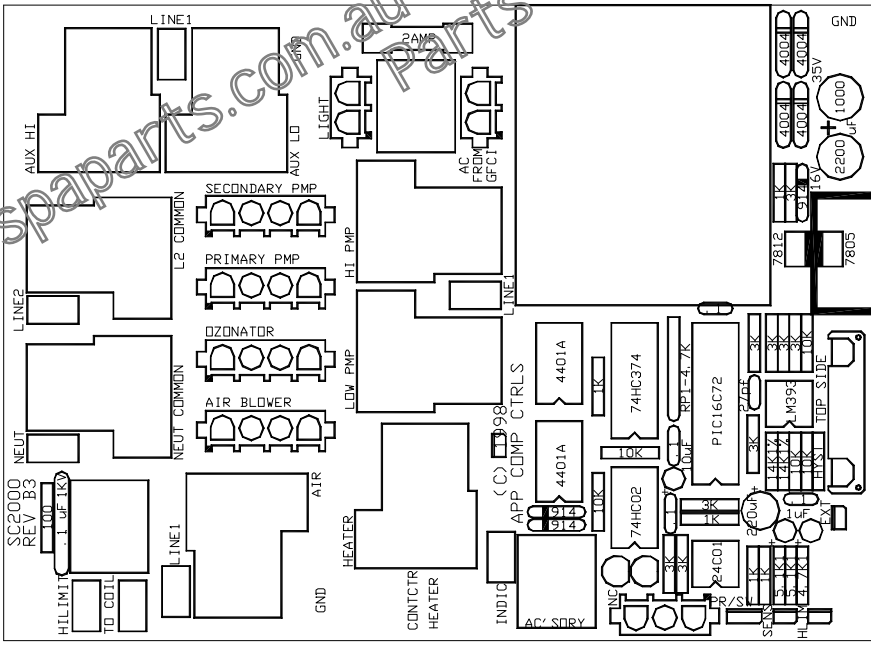

SC-2000 Control Board

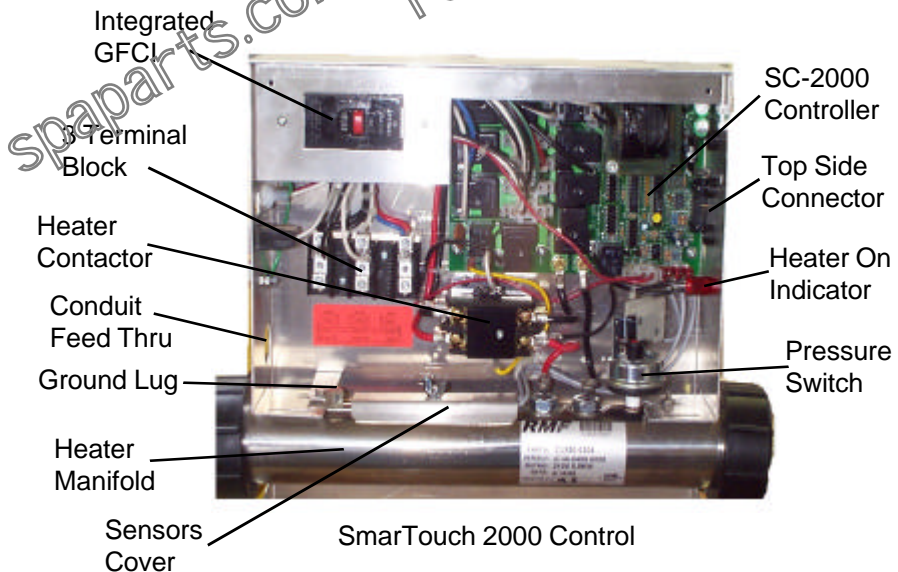
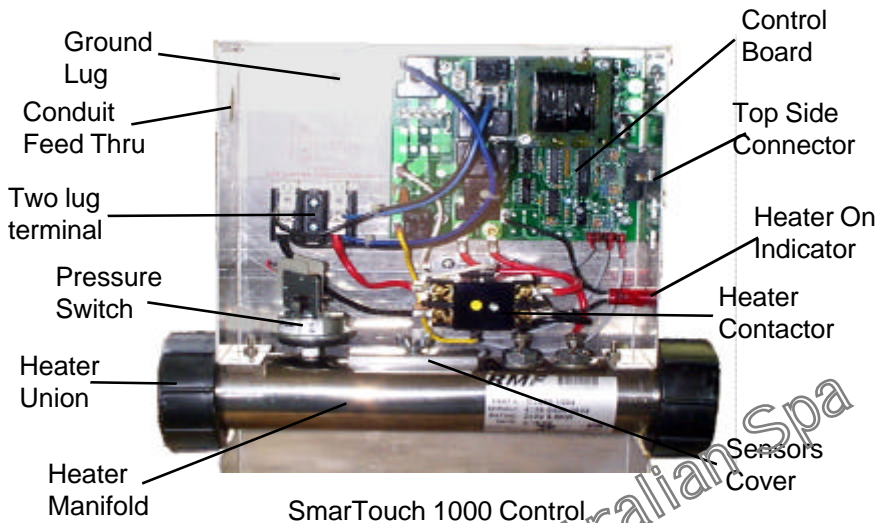

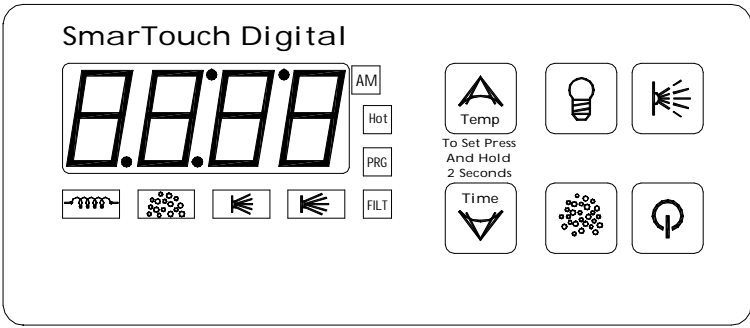

KP 1000 Spa Side Panel

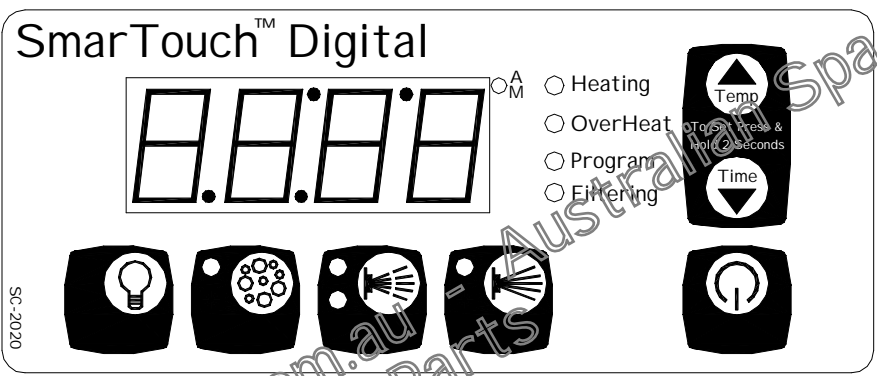

KP 2000 Spa Side Panel

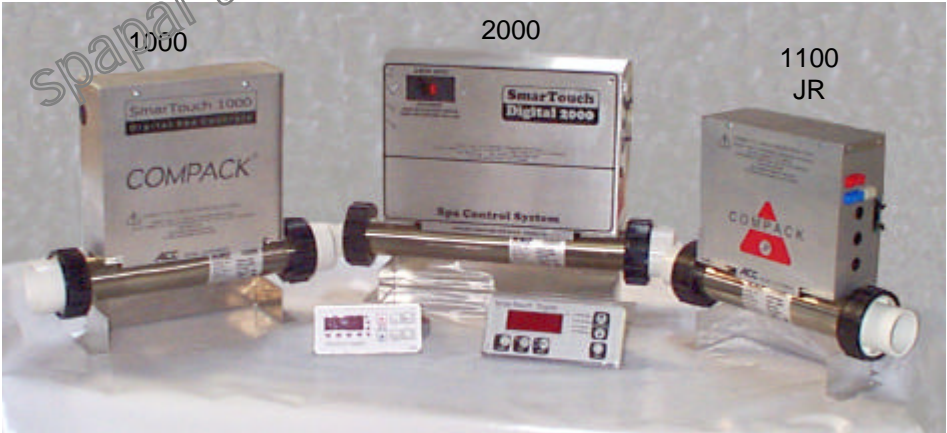

SmarTouch Digital 1000, 2000 & 1100JR

© 1999 Applied Computer Controls.
SmarTouch & SmarTouch Digital are trademarks of Applied Computer Controls.
 This manual may not be copied or reproduced without permission, in part or in total.