



Water, the Liquid of Life
www.waterco.com

Waterco Limited ABN 62 002 070 733

OFFICES - AUSTRALIA

NSW (HEAD OFFICE)

Sydney
Tel : +61 2 9898 8686
Fax : +61 2 9898 1754

QLD

Brisbane
Tel : +61 7 3299 9900
Fax : +61 7 3299 9911

WA

Perth
Tel : +61 8 9344 5533
Fax : +61 8 9344 5506

SA/ NT

Adelaide
Tel : +61 8 8244 6000
Fax : +61 8 8244 6011

VIC/ TAS

Melbourne
Tel : +61 3 9879 5141
Fax : +61 3 9879 5143

DISTRIBUTOR ACT

Canberra
Tel : +61 2 6280 6476
Fax : +61 2 6239 1395

OFFICES - OVERSEAS

NEW ZEALAND

Auckland
Tel : +64 9 525 7570
Fax : +64 9 525 6580

MALAYSIA

Kuala Lumpur
Tel : +60 3 6257 2711
Fax : +60 3 6257 3695

UNITED STATES OF AMERICA

Phoenix
Tel : +1 623 434 4703
Fax : +1 623 434 4704

CHINA

Guangzhou
Tel : +8620 8335 1107
Fax : +8620 8335 1114

EUROPE

Kent, United Kingdom
Tel : +44(0) 1795 521 733
Fax : +44(0) 1795 522 085

WATERCO
Water, the Liquid of Life

**POOL & SPA
ELECTRIC HEATERS**

SINGLE & THREE PHASE MODELS

OWNERS MANUAL



ELECTRIC POOL & SPA HEATERS

INDEX

General Information	1
Scope	2
Single Phase Heaters	2
Three Phase Heaters	2
Importance of Water Chemistry	2
Installation	3
* Plumbing Requirements	3
* Locating the Heater	3
* Electrical Requirements & Connections	4
* Changing the Heater Wattage (3 Ph)	4
* Changing the Heater Wattage (1 Ph)	5
* Adjusting the Pressure Switch	5
* Failure to Correctly Adjust the Switch	6
Troubleshooting	6
* Homeowner	6
* High limit Resetting Procedure	7
* Serviceman	7
* Cut-Out Faults	8
Routine Maintenance	8
Owner's Handy Hints	9
Specifications	9
* Heater Circuit Diagrams (3 Ph)	9
* Heater Circuit Diagrams (1 Ph)	9
Warranty, Disclaimer & Owners Information	10

- *Please keep this manual handy for future reference*

GENERAL INFORMATION

The Waterco Electric Pool & Spa Heaters are designed for domestic or commercial pool heating systems operating at 220-240 Volts single phase or 400-415 Volts three phase supply. Each heater is complete with all of its own safety and control devices, and requires no other controls for its safe operation. The heaters are designed to be simple to install with a minimum of in-field labour.

Installation should only be carried out by a registered electrician.

These heaters have full approval for use throughout Australia as a Prescribed Electrical Article, and carry the appropriate approval number.

SCOPE

These instructions cover all models of WATERCO Electric Pool & Spa Heaters.

SINGLE PHASE HEATERS

6kW POOL & SPA HEATER

A single phase general purpose plastic bodied pool & spa heater, using electronic control for water temperature management including electronic water presence detection. The heater contains separate water control and safety circuits. Electrical supply 240 VAC 25 amp/ min.

THREE PHASE HEATERS

18 AND 24kW 3 PHASE POOL HEATER

A stainless bodies three phase spa or pool heater designed for domestic or commercial pool heating. This heater uses electronic control for water temperature management including electronic water presence detection. Mechanical water pressure switch and two industrial quality contactors incorporating a manual reset over-temperature safety cut out device make this heater very robust & reliable. On site adjustment allows the heat output to be set at either full or half heat outputs depending on the requirements. This heater is designed for use on spa pools or swimming pools in Australia and may also be used on swimming pools in New Zealand. Electrical supply:

- * 18kW 415 VAC 25 amp min/ phase.
- * 24kW 415 VAC 35 amp min/ phase.

IMPORTANCE OF WATER CHEMISTRY

The Waterco pool or spa heater has been carefully designed to withstand the harsh environments of a spa system, and non metallic materials are used extensively. When metal parts are used however such as heater elements it is important that the water is chemically balanced to ensure that the water is not corrosive or scale forming. Waterco will not be responsible for damage caused by corrosion or scaling.

The chemical balance of water is a relationship between its pH, total alkalinity, calcium hardness and temperature. Your professional pool and spa shop can test the water to ensure that it is chemically balanced in accordance with the Langelier Saturation Index.

THE WATER MUST BE MAINTAINED AT ALL TIMES WITH A pH OF BETWEEN 7.2 & 7.8, A TOTAL ALKALINITY OF BETWEEN 80 AND 150ppm. A CALCIUM HARDNESS OF BETWEEN 150 AND 300ppm. AND WITHIN THESE TOLERANCES BE BALANCED TO THE LANGELIER SATURATION INDEX WITHIN A RANGE OF - 0.2 TO + 0.2.

NEVER DOSE YOUR POOL BY ADDING CHEMICALS VIA THE SKIMMER BOX

INSTALLATION

PLUMBING REQUIREMENTS

Ensure the heater is plumbed in accordance with local bylaws and good trade practice.

It is generally recommended to plumb the heater's inlet at the bottom and the outlet at the top. Heater will operate satisfactorily if plumbed in reverse.

If the heater is plumbed last in the return line ensure that sufficient water pressure is available to operate the pressure switch.

It is important to ensure that a good flow of water is available to the heater under all conditions of the pool and spa system.

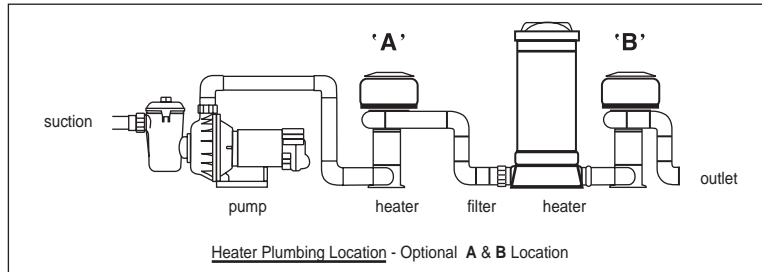

LOCATING THE HEATER

The heater should be located so that it is:

- Accessible for maintenance, inspection & operation.
- Vertical.
- In a sheltered position where possible, but may be installed without cover.
- Outside the pool or spa zone (as defined by AS 3000).
- Well ventilated (**max. ambient air temperature = 55°C**).
- In return water-line before the salt chlorinator or the chemical injection, and so that no backflow from chemicals or gas can occur into heater the use of a non return valve may be necessary.

ELECTRICAL REQUIREMENTS AND CONNECTIONS

The heater must be connected to the electrical supply in compliance with local Electrical Supply Authority bylaws and in accordance with sound trade practice. Installation must be carried out by a Registered Electrician, and the supply should be permanently connected via an isolating switch adjacent to the heater.

The heater electrical supply terminals provide for the connection of a Pilot/ Control supply. This should be used where a controlled tariff is required for the heater. It may also be used where a remote control for the heater is required. If pilot control is not used, simply loop to the active terminal next to the control terminal on single phase heaters, or refer to the wiring label in the three phase heaters.

Three phase heater elements are pre-wired in Star connection with the star point brought out to the neutral terminal. This connection arrangement must not be changed as the electronic controls and control contactor coils are rated at 240 Volts. If the element star point is not connected to neutral, multiple element failure may result.

CHANGING THE OUTPUT WATTAGE OF THREE PHASE HEATERS

All models of three phase heaters are designed to be DUAL WATTAGE. This provides the opportunity to make simple on SITE adjustments to provide full power or half power output is selected, it is essential that the correct value of overcurrent protection is provided at the switchboard. Overload protection should be provided at the board for the heater and to protect the heater supply cables.

To change the wattage, remove the links from the phase connections, as shown, to isolate one half of each element. Make sure all three elements are changed to maintain a balanced three phase load and to minimise the neutral current.

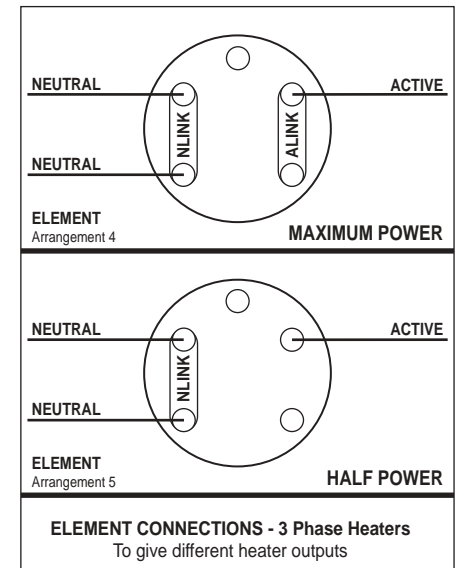

CHANGING THE OUTPUT WATTAGE OF SINGLE PHASE HEATERS

The provisions of the element links give the installer the ability to reduce the output of the single phase heater if desired. This may be necessary where supply cable limitations or local Supply Authority restrictions prevent the full output of the heater being used. By moving the links it is possible to downrate the heater to obtain half or quarter power as shown in Figure 3.

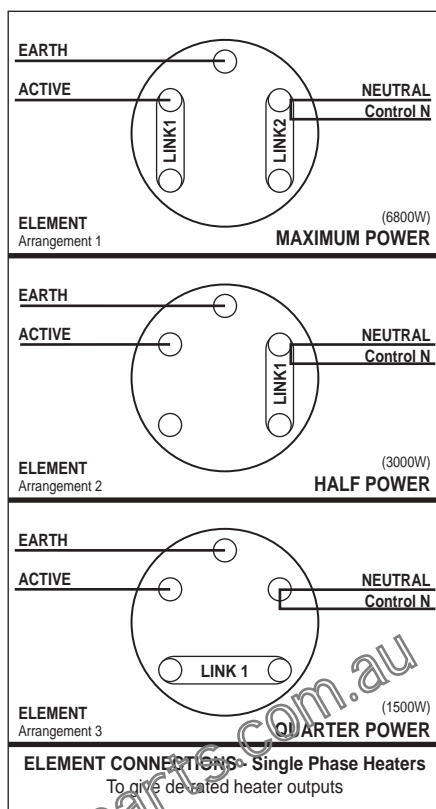

Fig.3 Element connections for de-rating single phase heaters.

ADJUSTING THE PRESSURE SWITCH

The pressure is the only field adjustment that must be checked after installation.

The switch is factory set and should not require adjustment if the heater is located at or slightly above pool water level (check it anyway). However, if the equipment is located below the level of the pool, the pressure switch must be adjusted to remove the effect of the static head of water. This will ensure that the heater turns OFF immediately when the pump stops running, and turns ON only when the pump starts.

Test for this condition at least twice.

FAILURE TO CORRECTLY ADJUST THE PRESSURE SWITCH WILL VOID THE WARRANTY

To adjust the pressure switch:

- Switch OFF the power to the heater.
- Ensure the filter is clean & run the pump with the filtration system as normal (FILTER MODE) until all the air is out of the system.
- Turn the pump OFF and check that the pressure switch turns OFF immediately or after a short delay (1 to 2 secs). If it is not possible to hear the pressure switch operate, connect an Ohmmeter across the Pressure Switch terminals.
- If the pressure switch remains ON after the pump stops, increase the operating pressure by turning the small adjusting screw (at the end opposite end of the terminals) slowly clockwise until the switch turns OFF.
- If the adjustment required is outside the range of this switch then a different switch or a flow switch will be necessary to protect the heater.
- Stop and start the pump several times to check the correct operation. Repeat if necessary.
- Return power to the heater.

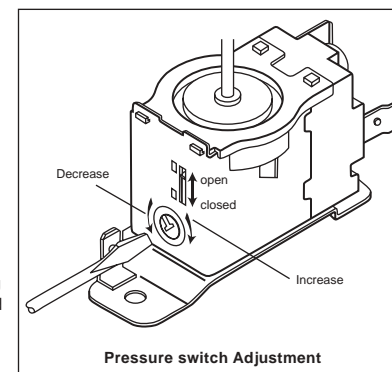

Fig.6 Pressure switch adjustment.

TROUBLESHOOTING

HOMEOWNER TROUBLESHOOTING

The heater should only be serviced by a Registered Electrician. However, if a fault is suspected, there are several things the homeowner can check before a serviceman is called in.

FAULT	CAUSE	REMEDY/ ACTION
Heater won't operate	No power to heater	Check Switchboard fuse. Check supply available under controlled tariff.
	Heater turned OFF	Turn ON isolating switch by heater.
	High limit cut-out has operated	Reset high limit cut-out, this cannot be done until pool cools below 40°C.
Pool or Spa won't reach temp	Thermostat not set high enough	Adjust control knob on front of heater.
	Air temperature around heater too high	Provide more ventilation around heater & filter pump.
	Heating time is insufficient	Check control box clock and reset if necessary to provide more running/ heating time.
	Heat loss too high	Pool not covered. Heater size too small for pool. Consult your WATERCO dealer.
	Insufficient water in heater	Pool water level has dropped below the level of the skimmer.

HIGH LIMIT RESETTING PROCEDURE

Resetting the heater requires use of a tool and exposes electrically live parts of the heater.

Manual reset button is located on the circuit board under the top cover.

1. Turn off power to heater at isolating switch.
2. Remove thermostat knob by loosening grub screw.
3. Remove cover by unscrewing retaining screw with screwdriver.
4. Push button, which is identified by arrow on the circuit board holder beside the thermostat.
5. Reassemble cover and knob securely.
6. Switch on power and test.

SERVICEMAN TROUBLESHOOTING

Troubleshooting should be carried out in a logical manner using the following chart as a guide.

FAULT	CAUSE	REMEDY/ ACTION
No power	Supply fault	Check fuse or MCB at Swbd.
	Heater turned OFF	Check isolating switch.
Not heating	No water in heater	Check isolating valves open.
	Air lock in heater	Re-plumb systems to eliminate air-locks. Re-prime system.
	Air in top heater chamber	Insufficient water flow. Clean filter. Check pump size. Check water level in pool.
	Safety High limit	Reset cut-out on PCB.
	Cut-out has operated	Established reason for tripping. (See 'Cut-out Fault' below)
	Pressure switch not set or faulty	Carry out setting procedure or replace.
	Faulty PCB or temperature sensor	Check operation. Replace as necessary.
	Faulty relay	Check operation. Replace as necessary.
Element fault	Replace element.	
	Pilot	Check the pilot switch is on or the electrical supply available under.....

CUT OUT FAULTS

Electronic Heater Controls

In the event of a control failure, the electronic High Temperature Limit cut-out will operate to de-energise the 'Safety Relay' (or the 'Control Relay' in 3 phase Pool Heaters). The cut-out is non self-resetting and if it is found to have operated, the cause should be established and the appropriate action taken to rectify the heater.

Causes for the tripping out are:

- High water temperature (45°C plus). See Resetting procedure.
- Temp. sensor fault (open or short circuit)
- Excessive heater internal air temperature
- Pressure switch not set to turn off when pump stop.

High water temperature can be caused by:

- Faulty control relay
- Thermostat turn too high or faulty

ROUTINE MAINTENANCE

Regular maintenance of the heater and controls will not normally be necessary. However, as most pool and spa systems operate in a hostile environment of high humidity and persistent chemical fumes, it is strongly recommended that the heater and control system is inspected and tested by a competent authorised tradesman on at least an annual basis.

Isolate the heater from the power supply.

The following points should be covered by this inspection;

1. Remove the cover and inspect for signs of water leaks or corrosion around the element boss and controls.
2. Check around water sensor probe connection and clean if necessary.
3. Disconnect element connections and Megger element. Reconnect.
4. Check for signs of overheating, cracking, distortion.
5. Check printed circuit board for signs for moisture, corrosion overheating etc.
6. Check the operation of the pressure switch. Ensure that it is switching on and off without excessive delay. Adjust or replace as necessary.
7. With the heater running, check the operations of the water presence detector by removing the 'water' sensor wire from the terminal block on top of the PCB. The control relay should turn OFF when the wire is removed, and turn ON after a short delay when it is replaced.
8. Every 2 to 3 years it is recommended that both the control relay and safety relay be replaced.

OWNERS HANDY HINTS

- Always switch OFF the heater when emptying the pool or cleaning the filter.
- Always ensure the water level is at the middle level of the skimmer opening.
- Always use a competent electrician familiar with pool and spa heaters to install or service the heater.
- Have the heater checked annually or before turning back on after an extended shut down period.
- Always ensure isolating valves in suction and return lines are open before switching ON after filter cleaning.
- Always maintain correct chemical balance of pool and spa water for your enjoyment and the protection of the spa support equipment. Failure to do so can void Warranty.
- Never clean the heater body or controls with solvents or petroleum base chemicals as these chemicals may attack the plastic material.
- Never add chemicals by tipping them in the pool skimmer box. Heavy concentrations of chemicals may damage the heater.
- A well insulated and covered pool will lose less heat & therefore cost less energy to run than a pool that is uncovered and/ or in an exposed position.

SPECIFICATIONS

Thermostat Temperature Adjustment	20°C to 40°C
High Limit Sensor	45°C
Pressure Switch	Preset On 35 kPa - 3.5m head Preset Off 15 kPa - 1.5m head
Maximum Pressure	350 kPa
Normal Maximum Operating Pressure	250 kPa
Maximum Allowable Temperature	55°C

Rated to IP 23 for use outside pool zone

MODEL	240V SINGLE PHASE MODEL	415V THREE PHASE MODEL
Height	360 mm	550 mm
Width	220 mm x 220 mm	250 mm x 400 mm
Material	Body flame retardant Noryl	Body 316SS
Cover	Flame retardant PVC	Flame retardant PVC

1. 415V 3 Phase 18kW or 24kW Heater

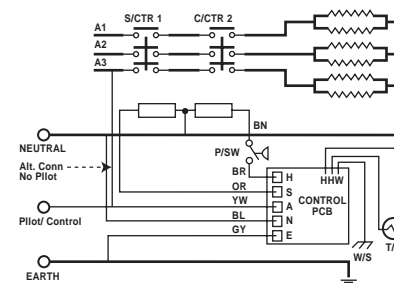

C/R CONTROL RELAY
S/R SAFETY RELAY
P/SW PRESSURE SWITCH
C/CTR CONTROL CONTACTOR
S/CTR SAFETY CONTACTOR
W/S WATER SENSOR
T/S TEMPERATURE SENSOR

2. 240V AC Single Phase 6kW Heater

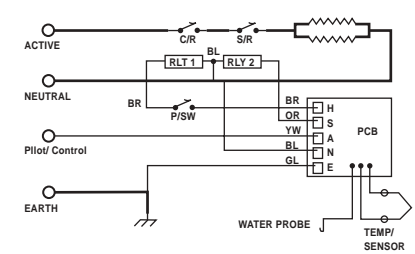

C/R CONTROL RELAY
S/R SAFETY RELAY
P/SW PRESSURE SWITCH
C/CTR CONTROL CONTACTOR
S/CTR SAFETY CONTACTOR
W/S WATER SENSOR
T/S TEMPERATURE SENSOR

TROUBLE FREE WARRANTY

Waterco Electric Pool & Spa Heaters are covered by Waterco Comprehensive Warranties, please refer to the separate Warranty Sheet for details.

DISCLAIMER

In the search for superior product performance or other factors, Waterco Limited reserves the right to alter the product in any manner at any time in the future, without prior warning.

The information is, to the best of our knowledge, accurate at the time of printing. Any recommendations or suggestions are made without warranty and without prejudice, since the use of our products is beyond our control.

OWNERS INFORMATION

For your records

Owner's Name :

Installation Date :

Installed By :

Serial Number :