

SPA PUMP INSTRUCTION MANUAL SX SERIES PUMPS

IMPORTANT SAFETY INSTRUCTIONS

When installing and using this electrical equipment, basic safety precautions should always be followed, including the following:

1.READ AND FOLLOW ALL INSTRUCTIONS

2.WARNING To reduce the risk of injury. Do not permit children to use this product unless they are closely supervised at all times.

3.WARNING Risk of Electrical Shock . Connected only to grounding type receptacle protected by a ground fault circuit interrupter (GFCI). Contact a qualified electrician if you cannot verify that the receptacle is protected by GFCI.

4.CAUTION Do not bury cord. Locate cord to minimize abuse from lawnmowers, hedge trimmers, and other equipment.

5.CAUTION In case the running parts will injure people, don't make the electric pump running before then pipeline have been connected.

6.WARNING To reduce the risk of electrical shock, replace damaged cord immediately.

7.WARNING To reduce the risk of electrical shock, do not use extension cord to connect unit electric supply; provide a properly located outlet.

8.CAUTION This pump is for used for fix-installed bath tub, It is not suitable for swimming pool spa.

9.Do not install within an outer enclosure or beneath the skirt of a hot tub unless so marked.

10.This appliance is not intended for use by young children or infirm persons unless they have been adequately supervised by a responsible person to ensure that they can use the appliance safely.

11.Young children should be supervised to ensure that they do not play with the appliance.

12.FOR INDOOR USE ONLY.

13.SAVE THESE INSTRUCTIONS.

14.Household use only.

15.Means for disconnection must be incorporated in the fixed wiring in accordance with the wiring rules.

16.In order to avoid a hazard due to inadvertent resetting of the thermal cut-out, this appliance must not be supplied through an external switching device, such as a timer, or connected to a circuit that is regularly switched on and off by the utility.



Do not dispose of electrical appliances as unsorted municipal waste, use separate collection facilities.

Contact you local government for information regarding the collection systems available.

If electrical appliances are disposed of in landfills or dumps, hazardous substances can leak into the groundwater and get into the food chain, damaging your health and well-being.

1.GENERAL

– These instructions are for correct installation, and optimum performance of the bath pumps, so they should be read carefully.

– These are single -stage centrifugal pumps designed to operate with compact hydromassage equipment, They are equipped with a total emptying system to prevent the discharge of residual liquid in each stopping.

– V/Hz esp: See pump nameplate.

– These units are designed to operate with clean water at a maximum water temperature of 50°C.

– Storage temperature: -10°C ~ +50°C. Relative Air Humidity:95% Max.

– Built of top quality materials, they are subjected to strict hydraulic and electrical controls and are carefully verified.

–Correct installation is ensured by following these instructions and those of the wiring diagram; otherwise, over loads may be produced in the motor. We decline responsibility for any damage caused by not following these instructions.

2.INSTALLATION

– Pumps must the level installment, Dimensions and position of the pump for supporting and fixing the pump within this space(Pig.3).

– Pump must be fixed by screw on the tub shelf, and fixed with silent block to lower the noise and libration. Sticking and enlacing is forbidden.

– The pump will be getting hot in operating , to speed up cooling, the minimum distance between the motor of the pump and the surrounding structure should not be less then 20mm.

– The suction, pipe of the pump should be as short as possible.

– The rating Label must be visible after installation.

– Parts containing live parts, except parts supplied with safety extra low voltage<12V, must be inaccessible to a person in the bath.

– Class I appliances must be permanently connected to fixed wiring. Part including electrical components except remote control devices must be located or fixed so that they cannot into bath.

3.PIPE ASSEMBLY

– The maximum inlet water pressure≤0.15MPa.

– The suction pipes should have a diameter equal to or larger than of the discharge pipes. It can avoid the loss of the head and improve the efficiency.

– The suction and discharge pipes should not rest above the pump in any case.

– Seal all the connectors and unions well. Avoid any dripping on the motor, which would unfailingly damage it.

– Should be use the new hose module which supplements along with the bathtub, the old hose module cannot be reused.

4.ELECTRICAL CONNECTION

– The electrical install action should have a multiple separation system with contacts opening at least 3mm.

– For continued protection against possible electric shock this unit is to be mounted to the base in accordance with the installation instructions.

1) The protection of the system should be based on a residual current device (RCD) with a rated tripping current not exceeding 30mA. The supply cable should comply with EMC standards.

2) Single-phase motors have built-in thermal protection.

– The electric connection must be carried out by qualified staff following strictly the "EN60335-2-60" standard.

– Be sure that the earth cable connection is correctly made.

– Wires serving as equipotential bonding conductors shall have a cross sectional area between 2.5 mm² and 6 mm² and shall be equipped with the terminal suitable receptacle.

5.CONTROLS PRIOR TO INITIAL START-UP

– Verify that the pump shaft turns freely.

– Check that the mains voltage and frequency are according to the name plate.

– The hydromassage assembly should be equipped with a system to prevent the pump from starting up if a minimum water level is not present.

– Check the rotating direction of the motor, which should concur with that indicated on the fan cover.

– If the motor does not start up, try to locate the problem in the table of most common faults and their possible solutions that is provided further on.

– **THE PUMP SHOULD NEVER OPERATE DRY.**

6.START-UP

- Start electrically the pump only when the suction and discharge pipes are connected to the corresponding inlets and outlets.
- Apply voltage to the motor and suitably adjust the jets to obtain the desired flow.

7.MAINTENANCE AND CLEAN !

- Our pumps for hydromassage facilities do not require any special maintenance or programming. If the pump will be idle for a long period of time , it is recommended to disassemble , clean and store it in a dry , well ventilated place. If the supply cord is damaged, it must be replaced by the manufacturer or its service agent or a similarly qualified person to a hazard.

8.TROUBLE SHOOTING GUIDE

SYMPTOM	POSSIBLE CAUSE	CHECK
PUMP DOES NO TURN	NO POWER TO PUMP	-Incoming power to the pump? -Is circuit breaker on? -Is GFCI operating properly? -Is the air switch plugged in?
	AIR SWITCH DISCONNECTED	-Is the air switch hose connected to the pump? -Is the air switch hose connected to the actuator button on the tub deck?
PUMP NOT PUMPING PROPERLY	BLOCKAGE OR LEAK	-Jets should be pointed away from the suction inlet so air is not forced into pump suction. -Is the in tub suction inlet blocked or covered? -Is there any debris in the pump housing? -Is there a leak in the piping or the pump?
	LOW VOLTAGE	-Is the proper voltage applied to the pump? -Is there an extension cord being used?

9.INSTALLATION DIAGRAM

As the colours of the wires in the mains lead of this appliance may not correspond with the coloured markings identifying the terminals in your connection unit proceed as follows.

The wire which is coloured green-and-yellow must be connected to the terminal in the connection unit which is marked with the letter E or by the earth symbol or coloured green or green -and-yellow.

Brown wire and Blue wire connected with power supply is low speed.

Black wire and Blue wire connected with power supply is high speed.

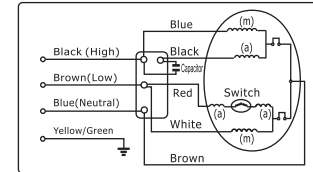

Fig.1

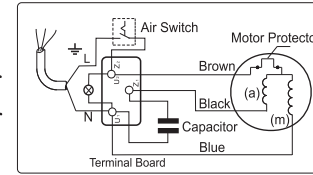

Fig.2

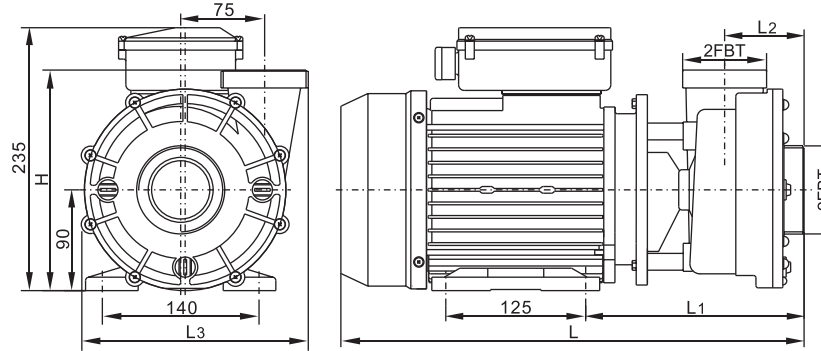
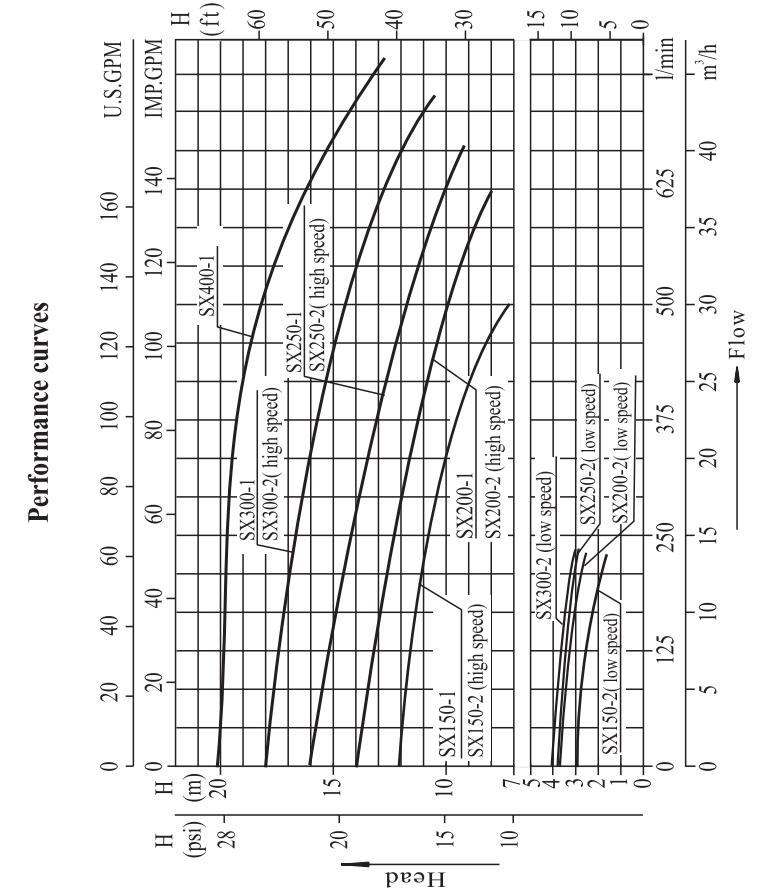

Fig.3

Model	Power(P _i)		L	L1	L2	L3	H
	kW	HP					
SX150-1	1.1	1.5	415	195	71	202	197
SX200-1	1.5	2.0					
SX250-1	1.85	2.5					
SX300-1	2.2	3.0					
SX400-1	3.0	4.0	421	202	76.5	211	210
SX150-2	(Low speed) 0.35	3/8	431	195	71	202	197
	(high speed) 1.1	1.5					
SX200-2	(Low speed) 0.35	3/8					
	(high speed) 1.50	2.0					
SX250-2	(Low speed) 0.40	1/2					
	(high speed) 1.85	2.5					
SX300-2	(Low speed) 0.45	5/8					
	(high speed) 2.20	3.0					



⚠ This appliance is not intended for use by persons (including children) with reduced physical, sensory or mental capabilities, or lack of experience and knowledge, unless they have been given supervision or instruction concerning use of the appliance by a person responsible for their safety. Children should be supervised to ensure that they do not play with the appliance. " SX200-2, SX200-1 can be connected only to a supply with system impedance no more than 0.454 ohm. In case necessary, please consult your supply authority for system impedance information." " SX250-1, SX250-2 can be connected only to a supply with system impedance no more than 0.400 ohm. In case necessary, please consult your supply authority for system impedance information." " SX300-1, SX300-2 can be connected only to a supply with system impedance no more than 0.351 ohm. In case necessary, please consult your supply authority for system impedance information."